



villiger

Speed Gripper

PICK UP ATTACHMENT



English



Speed-Gripper

Safe and efficient gripping of containers with mushroom hook

The Speed Gripper pick up attachment enables the gripping of all commercially available waste collection containers equipped with a mushroom hook, up to 3t total weight. The controlled gripping mechanisms allows for optimal power transmission and container alignment. Thus, maximum safety and efficiency are achieved.

The device is equipped with a hydraulic rotary feed-through block and a rotation motor. A patented clamping fixture for safe and precise container maneuvering is also integrated. The opening and closing mechanism of the container bottom is generated via a hydraulic arm device, which guarantees a speedy process.



Pick up attachment with integrated radio crane scale. The Speed Gripper VP 28 incl. a hydraulically folding appliance incl. a swing break. Folding appliance Type AFV 128.



Faster, safer, Speed-Gripper

Made to match any requirements

A device with the best possible handling security, as the container is held by the clamp in every situation. Thanks to the patented clamping fixture, the container can always be guided and no twisting in the device is possible. Once the

container is placed on the ground, only then does the clamping jaws release and the clamp can be unlocked. Afterwards the device can be uncoupled from the container.

Integrated valve control

Telescopic head below
Device sits on the container

Functions of the device:

- Mushroom bar lifting / closing
- Clamping jaws / closing
- No twisting possible

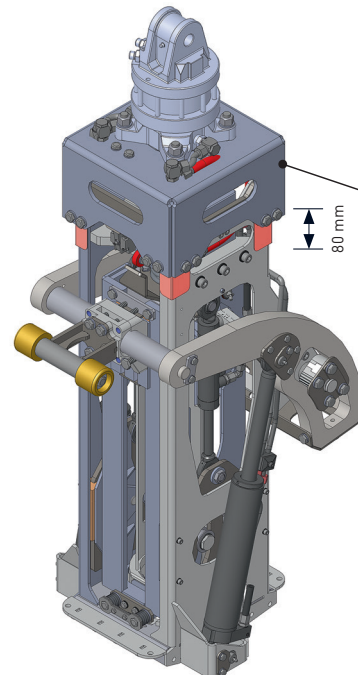
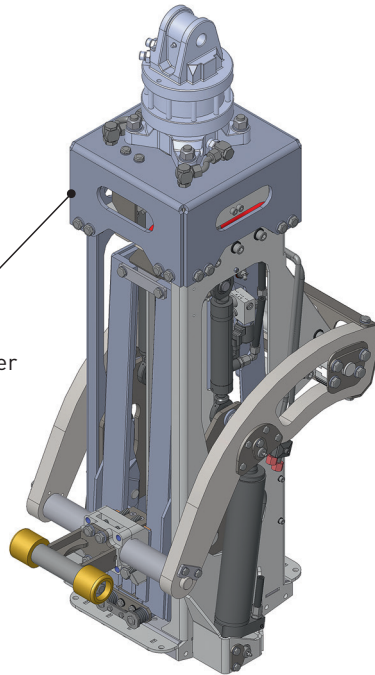

Telescopic head above
Device hangs on the crane

Functions of the device:

- 360° rotatable
- Bottom opening/closing
- Clamping jaws are locked

Your advantages

- Extremely speedy emptying process within 3 - 5 seconds
- Maximized safety during the container emptying procedure
- The container is firmly clamped in the device, no twisting possible
- Automatic stroke limitation, max. 500 mm
- Low extraction height
- Telescopic suspension with changeover valve
- Patented locking technology, thereby the container is held securely at all times
- Built-in swing brake for steady movements
- Spring-based and adjustable clip clamping jaws
- Double clamping jaws for a pick up of all conventionally available container systems according to DIN EN 13071-3
- Mushroom bar / chain is supported from two sides
- Usage of standard mushroom discs
- Large insertion funnel for fast positioning

Even more safety with Safety Pilot

The Safety Pilot is a battery-controlled locking valve that is independent from the Speed-Gripper, which locks both hydraulic cylinders on the clamping jaw. The Safety Pilot operates via the remote radio control.



The suitable device for every crane

A large variety of different loading cranes are in duty across the waste collection industry. However, our Speed-Gripper pick up attachment for mushroom containers can cope with all requirements. One hurdle that shouldn't be overlooked is the storage of such attachments during road haulage. Even for this, Villiger has developed a proper solution.



Z-loading crane with a Speed-Gripper VP 28 and folding appliance Type VPK 128.



Position the telescopic arm vertically and drive into the console.



Crane folding.



The device is in parking position, crane is folded.

Folding appliance Type VPK 128 (swan neck)

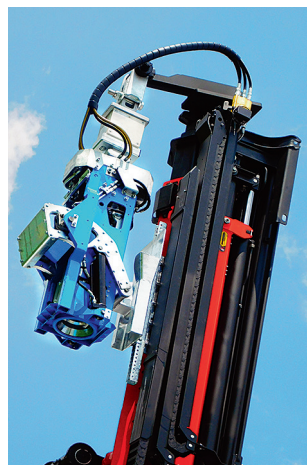
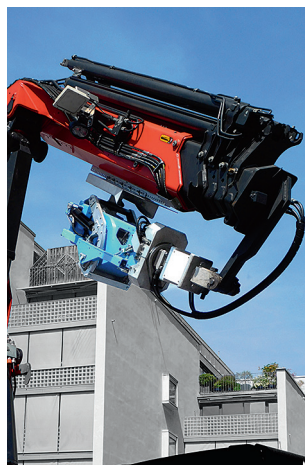
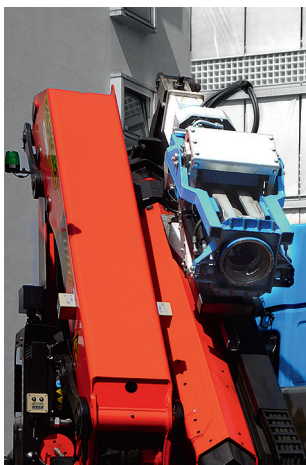

Pick up device incl. Swing break and a radio crane weighter.

Compatible with all commercially or conventionally available crane systems

Commercial crane systems can be supplemented with a Villiger Speed-Gripper VP 28 device. Its hydraulic is compatible with open or closed slides (crane setup). The hydraulic head enables a unique rotation of 360°. The funnel-enabled centering makes positioning on the mushroom hooks very easy. Additionally, a swing break and the telescopic suspension reduce unwanted movements. All-in-all, this allows for a smooth emptying process.

Provides more movements

Moving big things requires a container pick up device that can meet all sorts of special requirements and fits perfectly into the waste collection processes. With the Speed Gripper VP 28 you get even more out of your daily operations.



Roof crane with a Speed-Gripper VP 28. To retract into the overhead parking position Type VPD 128.

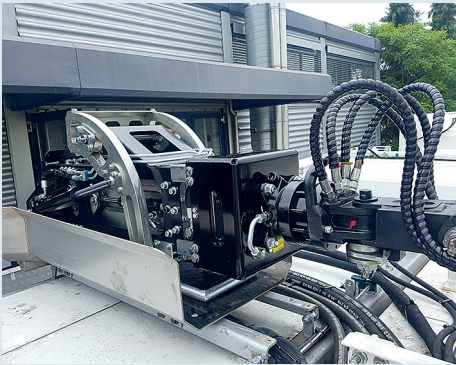

Device stays in its parking position.



Tipping of the tailgate.



Device is parked at the tailgate, Parking console Type VPH 028

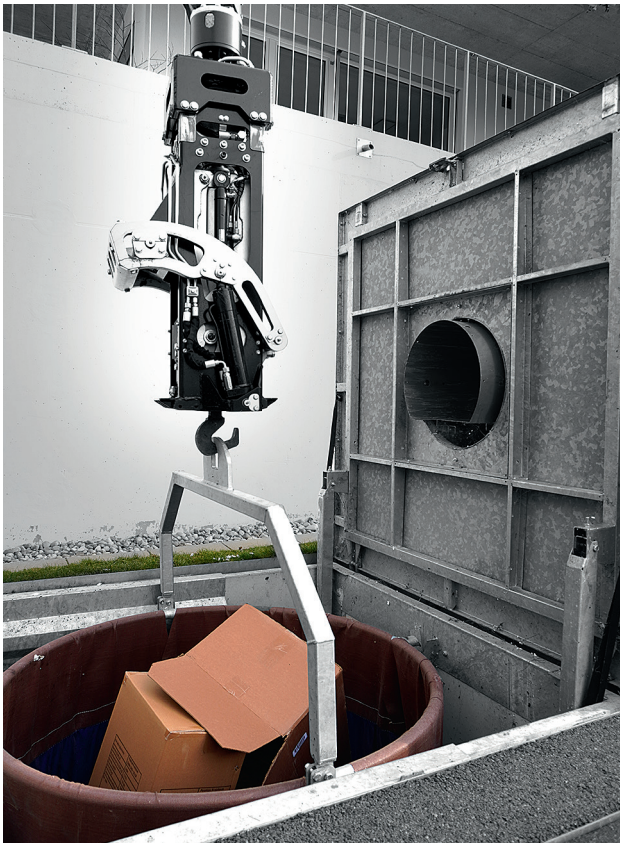

Speed-Gripper with a one hook adapter Type VPV 020.



Speed-Gripper with custom folding appliance Type VP 128.

After Sales

- Spare Parts
- Live Demonstration
- Lease
- Service / Renovation
- Service & Maintenance contracts

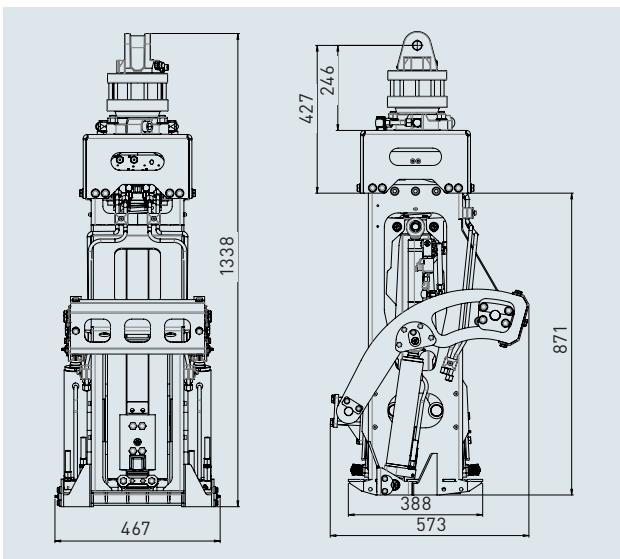

Technical Datas:

Tare weight: 240 kg
 Working load: 2500 kg / 3000 kg
 Operating pressure: 210 bar
 (max. pressure hedged with shock valves)

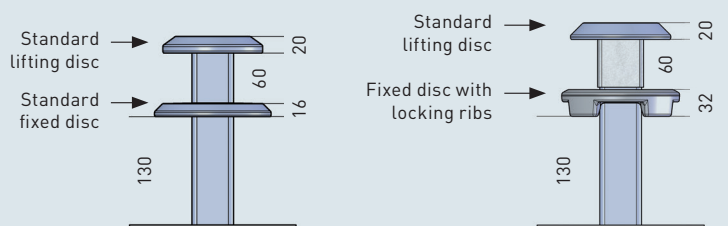

Speed-Gripper VP 28

Patent protected

With clamping jaws for standard fixed discs, 16 mm

Conventional mushroom hook with mushroom bar or chain

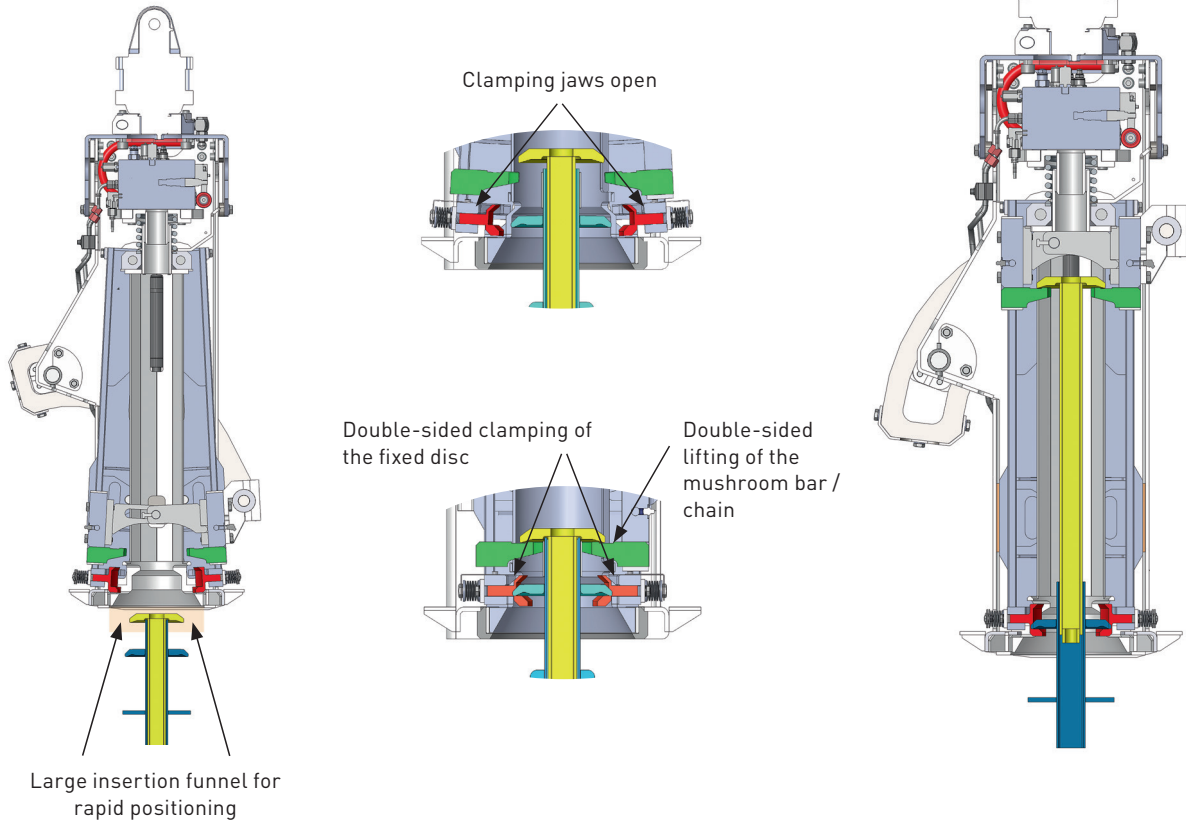

Speed-Gripper VP 28-2

With clamping jaws for fixed discs of 16 mm

and locking ribs of 32 mm

Conventional mushroom hook with mushroom bar or chain

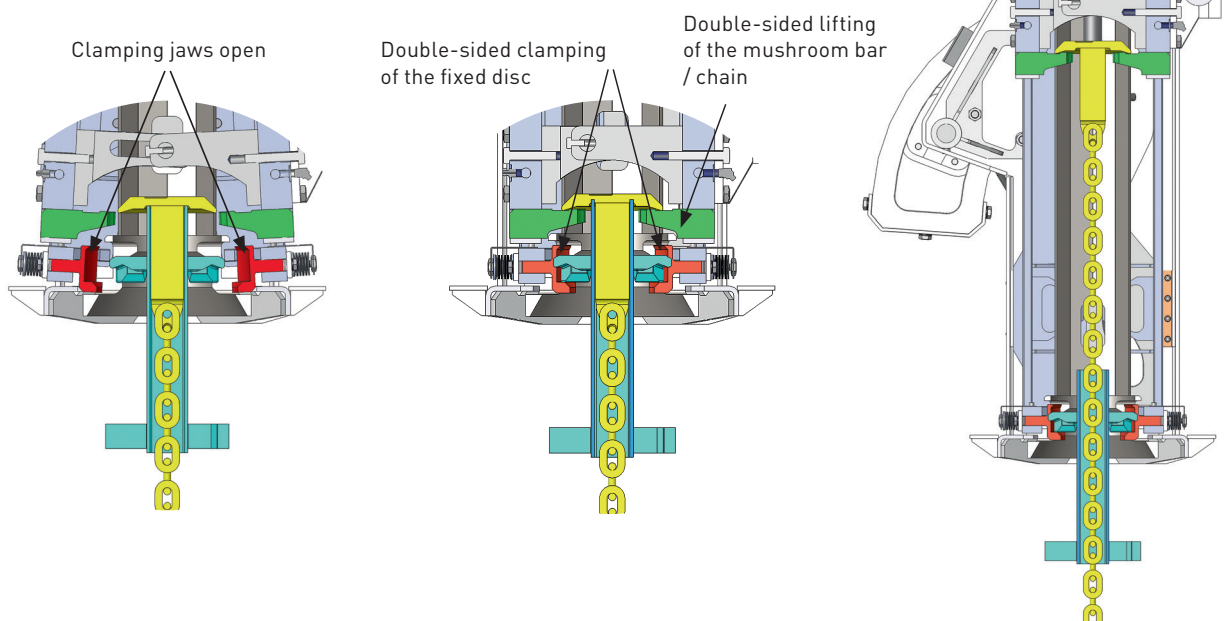

We reserve the right to make changes in the event of further development.

Manual pick up attachment for mushroom MPA 20

Only the designated pick up devices provide the necessary safety to lift a container without hazard. Thanks to the Villiger manual pick up device MPA 20, you are able to move all mushroom hook enabled above- or underground containers with any conventional crane.

The device MPA 20 persuades with its low work height, compact engineering and robust mechanic. Thus, you are independent in every situation and hydraulic connections are needless. Containers with a mushroom hook can be lifted and moved safely without a modification. On a solid surface, the mechanism can be unlocked to open or close the bottom.

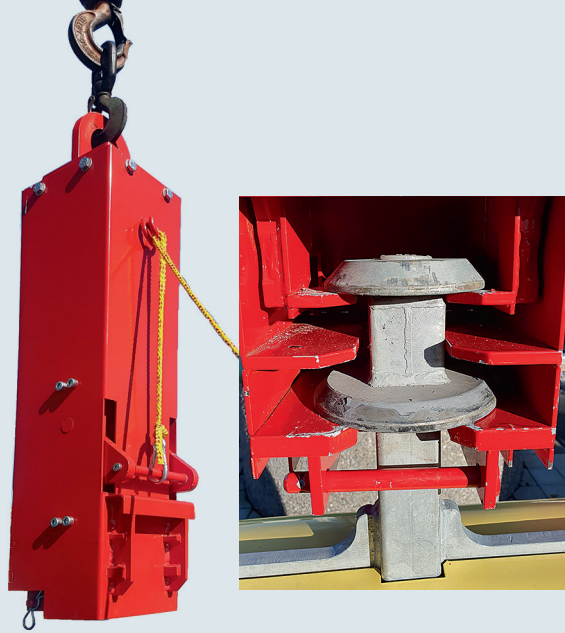

Operation area and functionality

The Villiger MPA 20 manual pick up device for mushroom hooks is particularly suitable for fire departments, municipal operation centers, service providers, waste collection companies, and for anyone who needs to lift, move or empty individual containers. Via a pull rope, the mechanism can be activated, that the container can be lifted with a locked or open bottom.

Technical datas:

Pick up weight:	up to 2 tons
Tare weight:	approx. 30 kg
Color:	Red
Scope of Delivery:	Pick up device incl. dragline



Lifting with a locked and closed container bottom.



Moving of the container with open bottom.



Safety Warning

Lift the container only with a designated lifting device. Never use any tension belts, chains, etc. This will prevent damage and unwanted emptying procedures.



Villiger Public-Systems GmbH
Bahnhofstrasse 13, CH-5647 Oberrüti
Tel.: +41 41 784 23 23
info@villiger.com

Villiger Entsorgungssysteme GmbH
Adolf-Kolping-Str. 1/1, DE-88433 Schemmerberg
Tel.: +49 7356 86 431 0
info.de@villiger.com

villiger.com

